

BIG BLASTER® XHV Air Cannon Retrofit Kit Installation Instructions



Warranty disclaimer

Martin Engineering's warranty for this product is limited to the item or items manufactured by Martin Engineering that accompany this instruction sheet. The warranty of Martin Engineering that accompanies this product is limited to that product and does not extend to any pressure vessel or other item not manufactured by Martin Engineering to which Martin's product is connected or attached. Martin Engineering specifically disclaims any warranty or liability for property damage, injury, or other loss if Martin's product is attached, connected, or otherwise used in conjunction with non-Martin products.

Inspection Instructions

▲ WARNING

Before retrofitting with the XHV Valve Assembly, inspect existing air cannon mount, pressure vessel, control system, air supply system, and structure walls. If you have any doubts or concerns about the integrity of any of these components, DO NOT RETROFIT. Failure to inspect can result in damage to property and injury to personnel.

1. **Inspect mount** for wear, broken or cracked welds, and loose fasteners. If any exist, repair or replace before retrofitting. If you have doubts or concerns about the integrity of the mount, do not retrofit.
2. **Inspect pressure vessel** (air cannon tank):
 - a. Make sure pressure vessel was manufactured according to governing body codes and specification on pressure vessel construction (i.e., American Society of Mechanical Engineers [ASME] or CE codes). If pressure vessel was not manufactured according to ASME or CE codes, do not retrofit.
 - b. Visually inspect interior and exterior of pressure vessel for cracked welds, rust, metal pitting, and damage. If any exists, repair or replace before retrofitting.
 - c. Inspect safety relief valve. If valve does not relieve pressure when actuated, replace before retrofitting.
 - d. If you have any doubts or concerns about the integrity of the pressure vessel, do not retrofit.
3. **Inspect control system** for operation. Repair or replace any defects before retrofitting.
4. **Inspect air supply system** for operation and leaks. Repair or replace any defects before retrofitting.

Inspect structure walls. If wall thickness is less than 1/4 in. (6 mm) for steel walls or 3/8 in. (9 mm) for aluminum walls, contact Martin Engineering before retrofitting. For cement walls, inspect for cracks. If any exist, do not retrofit.

Installation

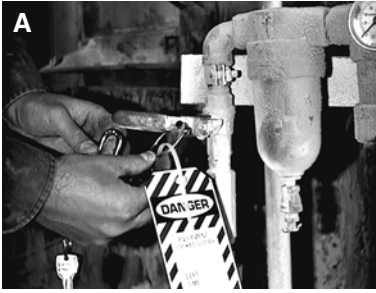

⚠ WARNING

Turn off and lock out/tag out air supply and energy source before blasting air cannon to prevent air cannon from refilling.

Do not open door/port or enter structure before turning off compressed air source, locking out controls, purging line pressure, and venting air from tank. Opening structure door while cannon is operational can kill you.

1. Turn off and lock out/tag out energy source (A) according to American National Standards Institute (ANSI) z244.1-1982 and Federal Register, Volume 54, Number 169, Part IV, 29 CFR Part 1910.
2. Blast air cannon to remove air from tank. If tank has a relief valve, pull ring to make sure air stored in cannon has been released. Disconnect air hoses.



3. Remove safety cable (B) and quick exhaust valve (QEV) (C) (if present) from existing air cannon. Remove existing cannon from its mount (D). (IMPORTANT: Martin Engineering recommends using QEV P/N 18858 with XHV Valve Assembly. Other valves will not work as efficiently with the XHV.)



4. Remove existing piston/cylinder mechanism from tank (E).
5. If necessary, plug current air inlet fitting on tank with supplied plug (F).
6. Position supplied gasket on tank flange (G).



7. Position XHV valve assembly over gasket and secure with fasteners (H). Tighten to snug.



8. Position XHV discharge flange on existing mount and install fasteners (J). Tighten securely.
9. Tighten fasteners securing XHV valve assembly to tank.

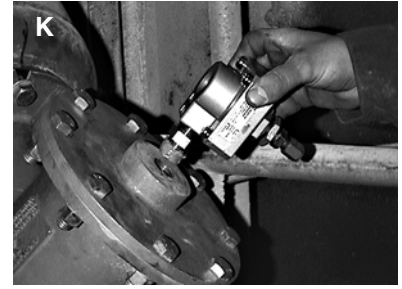

10. Apply thread sealant compound to both ends of nipple and install in QEV. Install QEV into rear of XHV unit with exhaust port pointing down and away from personnel (K).

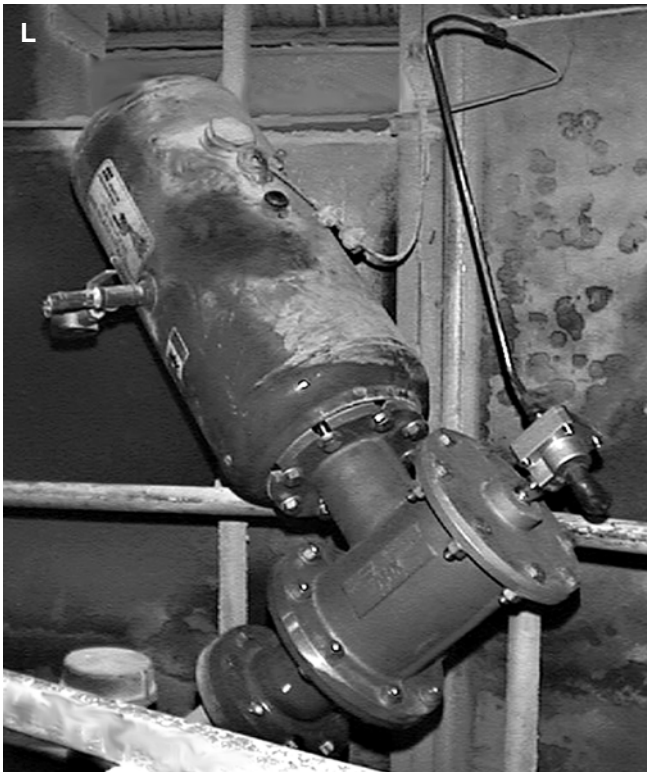

11. Connect existing air supply to QEV inlet port and re-install safety cable (L).

⚠ WARNING

Do not exceed your air cannon tank's maximum working pressure or tank can explode. If you are unsure about the maximum pressure, consult your original air cannon's documentation.

12. Charge air cannon to original air pressure specification and check for air leaks in piping system.

⚠ WARNING

Air cannon may produce loud noise when blasting. Wear ear protection to avoid impairment or loss of hearing.

13. Blast air cannon five times to ensure proper operation. Allow tank to fill after each blast.
14. If air cannon blasts properly, continue to operate air cannon as needed. If air cannon does not blast properly, contact Martin Engineering for assistance.
15. Thoroughly wipe storage vessel wall clean next to structure door/port. Place Air Blast Warning Label, P/N 31913, on structure wall visible to anyone opening door/port. If structure has more than one door or port, request additional labels from Martin Engineering or representative.

⚠ WARNING

Shutting off lockout ball valve will purge all cannons connected to that valve and cause the air cannons to fire immediately. Do not shut off the valve until you make sure no one is in the structure or near its discharge. Flying debris from the cannons' blast can kill you.

16. If using lockout ball valve on piping to air cannon, attach Lockout Valve Warning Tag, P/N 35146, to lockout valve using supplied cable tie.



Part Numbers

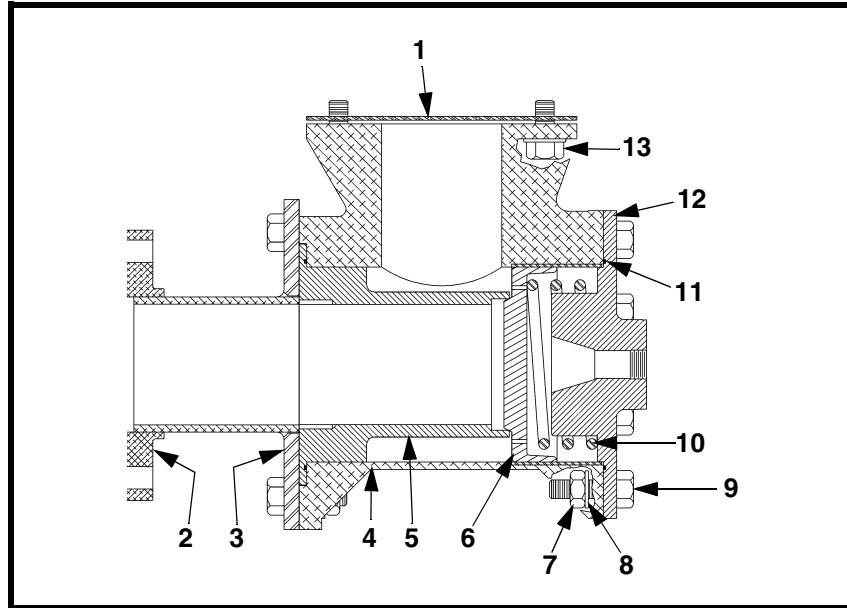

Item	Description	Part No.	Qty
1	Gasket Tank	35080	1
2	Flange 4-NPT Threaded RF	23213 ^{††}	1
3	Discharge Flange Weldment	35081	1
4	Valve Body	35076	1
5	Seat Piston	35075	1
6	Piston	37962	1
7	Nut	Tbl I	Tbl II
8	Washer Compression	Tbl I	Tbl II
9	Screw Hex Head Cap	18831	Tbl II
10	Spring Compression	35077	1
11	O-Ring	35078	2
12	Valve Body Cap Assembly	35073	1
13	Screw Hex Head Cap	Tbl I	8
14 (NS)	Plug Pipe 3/4 -NPT	18446-01	Tbl II
15 (NS)	Plug Pipe 1/2 -NPT	21874	Tbl II
NS	Quick Exhaust Valve	18858*	1
NS	Nipple Hex 3/4 -NPT	18308	1
NS	Air Blast Warning Label	31913	1
NS	Lockout Valve Warning Tag	35146	1
NS	Noise Warning Tag	34070	1
NS	MARTIN® BIG BLASTER® XHV Air Cannon Operator's Manual	M3404	1

Figure 1. BIG BLASTER® XHV Retrofit, P/N 35082-X[†]

*Order separately; not included in assembly.

[†]Replace X with letter designating type of cannon being replaced (see Table I).

^{††}Cannot be used with assemblies 35082-B or 35082-E.

Table I. BIG BLASTER® XHV Retrofit Part Numbers

Cannon Model Replaced	Part Numbers			
	XHV Assy	Item 7	Item 8	Item 13
<ul style="list-style-type: none"> •MARTIN® Internal/External BB4 •GLOBAL® GW4 •VIBCO® ABS-4 	35082	11772	11752	15798
AIRCHOC® AC2	35082-A	11772	11752	14205
BRELKO® BB 050, 100, and 200	35082-B	11772	11752	22519
Martin Engineering GmbH. BB4	35082-E	11772	11752	—
<ul style="list-style-type: none"> •LADCO® HV 154, 504, and 654 •HOSCH® AB 50NT, 100NT, and 200NT 	35082-L	11772	11752	22519

Table II. BIG BLASTER® XHV Retrofit Item Quantities

Assembly Part No.	Item Quantities				
	7	8	9	14	15
35082	24	24	16	1	1
35082-A	24	24	16	0	0
35082-B	24	24	16	1	0
35082-E	16	16	16	1	0
35082-L	24	24	16	0	0

AIRCHOC® is a registered trademark of Standard Industrie S.A.

BRELKO® is a registered trademark of Brelko Conveyor Products

GLOBAL® is a registered trademark of Global Manufacturing, Inc.

HOSCH® is a registered trademark of Hosch Fordertechnik GmbH

LADCO® is a registered trademark of Long-Airtox Company

VIBCO® is a registered trademark of VIBCO, Inc.

QUALITY MANAGEMENT SYSTEM
CERTIFIED BY DNV

== **ISO 9001** ==

Form No. M3405-10/10

© 1997, 2010 MARTIN ENGINEERING COMPANY. All rights reserved.

Patents and patents pending. ® Registered trademark of
Martin Engineering Company in the U.S. and other select locations.

martin®

One Martin Place
Neponset, IL 61345-9766 USA
Phone: 309-852-2384 or 800-544-2947
FAX: 800-814-1553
www.martin-eng.com